



Summit SKILLS



Overflowing with talent?

SkillPLUMB 2010 In-House Skills Competition

General Information

Competition requirements:

- Each potential competitor should complete the competition task.
- The college tutor should mark the work of each competitor according to the marking scheme overleaf.
- The competitor with the highest score should be entered into SkillPlumb

We recommend that this test should take approximately 4–6 hours to complete

The test is carried out in copper and steel tube and is designed to test the following skills:

- Interpreting drawings and pipe details
- Measuring, fitting and installation requirements
- Measuring, marking out and cutting copper/steel tube
- Bending copper / steel tube by machine
- Jointing copper tube by capillary soft solder method

Standards

The standards of work required to gain maximum marks are:

- The measurements should be within +/- 2mm of the specifications
- The bends should be within +/- 1° of the specifications
- The soldered fittings should not be burnt, wiped or have drips.
- There should be no burrs at the end of the pipes
- There should be between 1 to 2 threads showing on all screwed joints.

Safe Working

- Candidates must work safely at all times and take the appropriate precautions when working with any tools that have a potential safety hazard.
- Eye and foot protection to be worn at all times.
- No power tools to be used with the exception of a battery powered drill.



This competition specification was devised by the WorldSkills UK expert plumbing training manager.

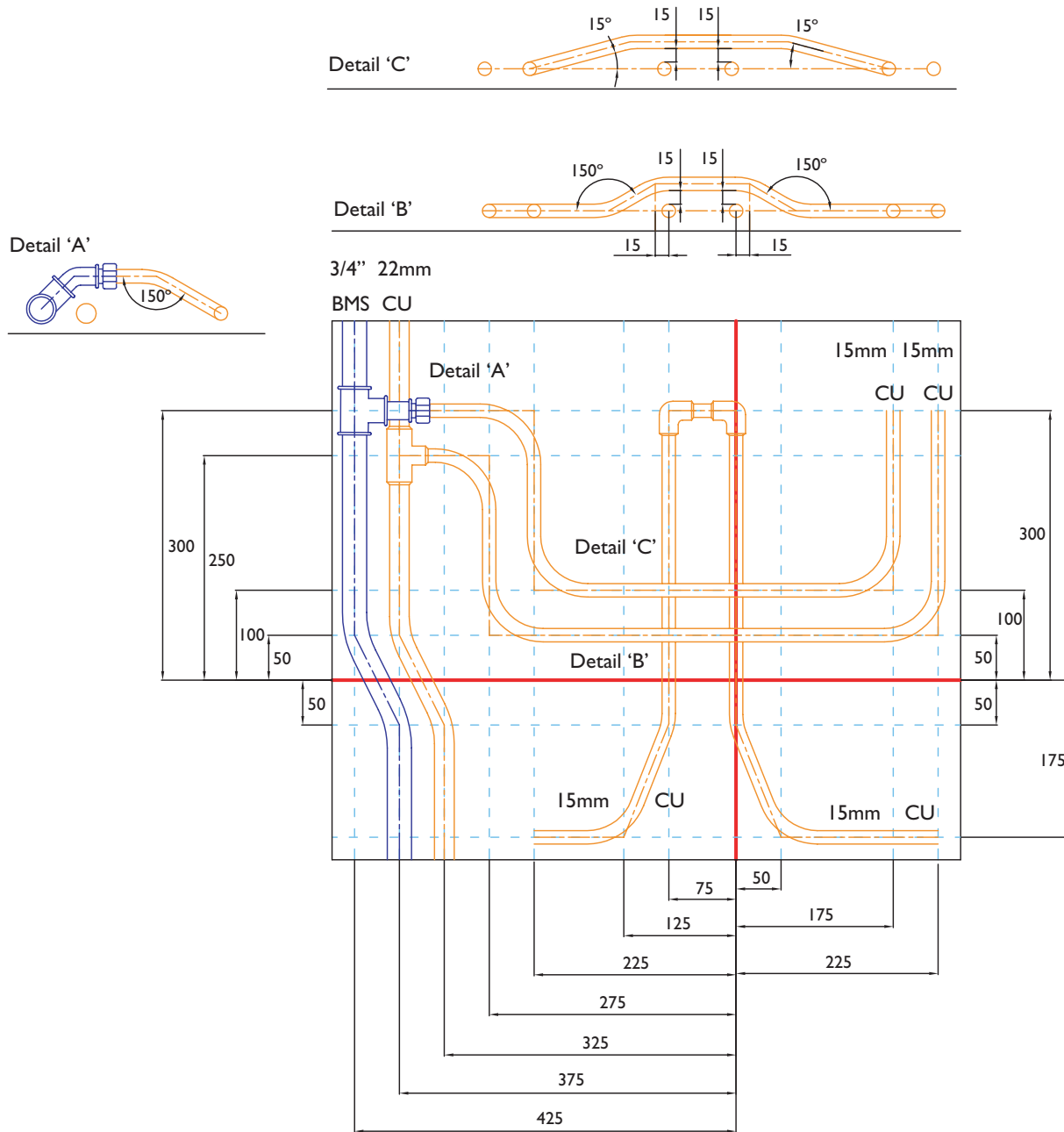

Drawing notes

1. The work area measures 700mm by 600mm.
(The task can be completed on a board or a wall)
2. The horizontal datum is 200mm from the bottom edge of the board.
3. The vertical datum is 250mm from the right hand edge of the board.
4. All bends are made by machine.
5. Only six fittings are required. The rest of the pipework is bent.
6. All pipes to be fitted as per drawing.

Marking Schedule

College / Training Provider:

Assessor's Name and Signature:

Competitor's Name:

Final Score (100 max):

Left Hand Side of Vertical Datum – Above Horizontal Datum

Aspect of Criterion	Actual	Mark
15mm Pipe vertical above top Passover (+/- 2mm = 2 marks, +/- 4mm = 0.5 marks) from vertical Datum	75	
15mm Pipe vertical mid-point between bends (+/- 2mm = 2, +/- 4mm = 0.5) from vertical Datum	225	
15mm Pipe vertical mid-point between bends (+/- 2mm = 2, +/- 4mm = 0.5) from vertical Datum	275	
22mm Pipe vertical mid-point between tee & bend (+/- 2mm = 2, +/- 4mm = 0.5) from vertical Datum	375	
_” Pipe vertical mid-point between tee & bend (+/- 2mm = 2, +/- 4mm = 0.5) from vertical Datum	425	
15mm Pipe Horiz.mid-point between bend & Datum (+/- 2mm = 2, +/- 4mm = 0.5) from Horiz. Datum	50	
15mm Pipe Horiz.mid-point between bend & Datum (+/- 2mm = 2, +/- 4mm = 0.5) from Horiz. Datum	100	
Centre of _” x _” Tee Pipe horiz. (+/- 2mm = 2, +/- 4mm = 0.5) from Horiz. Datum	300	
Centre of 22mm x 15mm Tee Pipe horiz. (+/- 2mm = 2, +/- 4mm = 0.5) from Horiz. Datum	250	
_” Bend centre from Horiz. Datum (use a template) (+/- 2mm = 2, +/- 4mm = 0.5) from Horiz. Datum	50	
22mm Bend centre from Horiz. Datum (use a template) (+/- 2mm = 2, +/- 4mm = 0.5) from Horiz. Datum	50	
_” BMS to end of pipe from Horiz. Datum (+/- 2mm = 2, +/- 4mm = 0.5) from Horiz. Datum	400	
22mm Cu. to end of pipe from Horiz. Datum (+/- 2mm = 2, +/- 4mm = 0.5) from Horiz. Datum	400	
All Joints free from burning, not wiped and no drips	(yes = 6 no=0)	Yes/No
Total (Max 32)		

Right Hand Side of Vertical Datum – Above Horizontal Datum

Aspect of Criterion	Actual	Mark
15mm Pipe vertical mid-point between bend & End (+/- 2mm = 2 marks, +/- 4mm = 0.5 marks) from vertical Datum	175	
15mm Pipe vertical mid-point between bend & End (+/- 2mm = 2, +/- 4mm = 0.5) from vertical Datum	225	
15mm Pipe Horiz.mid-point between bend & Datum (+/- 2mm = 2, +/- 4mm = 0.5) from Horiz. Datum	50	
15mm Pipe Horiz.mid-point between bend & Datum (+/- 2mm = 2, +/- 4mm = 0.5) from Horiz. Datum	100	
Left hand 15mm bend 90° (+/- 1° = 2 Over = 0)	90°	
Right hand 15mm bend 90° (+/- 1° = 2 Over = 0)	90°	
15mm Cu. to end of pipe from Horiz. Datum (+/- 2mm = 2, +/- 4mm = 0.5) from Horiz. Datum	300	
15mm Cu. to end of pipe from Horiz. Datum (+/- 2mm = 2, +/- 4mm = 0.5) from Horiz. Datum	300	
Total (Max 16)		

Left Hand Side of Vertical Datum - Below Horizontal Datum

Aspect of Criterion	Actual	Mark
15mm Pipe vertical at Horiz. Datum (+ 2mm = 2, + 4mm = 0.5) from vertical Datum	75	
15mm Pipe vertical mid-point between bend & End (+ 2mm = 2, + 4mm = 0.5) from vertical Datum	425	
22mm Pipe vertical mid-point between bend & End (+ 2mm = 2, + 4mm = 0.5) from vertical Datum	375	
15mm Bend centre from Horiz. Datum (use a template) (+ 2mm = 2, + 4mm = 0.5) from Horiz. Datum	50	
15mm Bend centre from Horiz. Datum (use a template) (+ 2mm = 2, + 4mm = 0.5) from Horiz. Datum	175	
15mm Pipe Horiz. mid-point at End (+ 2mm = 2, + 4mm = 0.5) from vertical Datum	175	
15mm Cu. to end of pipe from Vertical. Datum (+ 2mm = 2, + 4mm = 0.5)	225	
Total (Max 14)		

Details

Aspect of Criterion	Actual	Mark
Detail 'A' bend 150o (+/- 1° = 2 Over = 0) (use a template)	150°	
Detail 'B' Left bend 150o (+/- 1° = 2 Over = 0) (use a template)	150°	
Detail 'B' Right bend 150o (+/- 1° = 2 Over = 0) (use a template)	150°	
Detail 'C' Left bend 150 (+/- 1° = 2 Over = 0) (use a template)	15°	
Detail 'C' Right bend 150 (+/- 1° = 2 Over = 0) (use a template)	15°	
Detail 'B' Left pipe Passover clearance (+ 2mm = 2, + 4mm = 0.5)	15	
Detail 'B' Right pipe Passover clearance (+ 2mm = 2, + 4mm = 0.5)	15	
Detail 'C' Left pipe Passover clearance (+ 2mm = 2, + 4mm = 0.5)	15	
Detail 'C' Right pipe Passover clearance (+ 2mm = 2, + 4mm = 0.5)	15	
15mm BSP to 15mm copper connector 1 to 2 threads visible (No = 0, Yes = 2)	Yes/no	
15mm Branch on tee 1 to 2 threads visible (No = 0, Yes = 2)	Yes/no	
15mm Bottom joint on tee 1 to 2 threads visible (No = 0, Yes = 2)	Yes/no	
15mm Top joint on tee 1 to 2 threads visible (No = 0, Yes = 2)	Yes/no	
Total (Max 26)		

Right Hand Side of Vertical Datum - Below Horizontal Datum

Aspect of Criterion	Actual	Mark
15mm Pipe vertical at Horiz. Datum (+ 2mm = 2, + 4mm = 0.5) from vertical Datum	0	
15mm Bend centre from Vertical Datum (use a template) (+ 2mm = 2, + 4mm = 0.5) from Horiz. Datum	50	
15mm Bend centre from Horiz. Datum (use a template) (+ 2mm = 2, + 4mm = 0.5) from Horiz. Datum	175	
15mm Cu. to end of pipe from Vertical. Datum (+ 2mm = 2, + 4mm = 0.5)	225	
Total (Max 8)		

Health & Safety

Aspect of Criterion	Actual	Mark
Eye protection worn all time (No = 0, Yes = 2)	Yes/No	
Heat resistant gloves worn whilst carrying out hot work (No = 0)	Yes/No	
Total (Max 4)		